

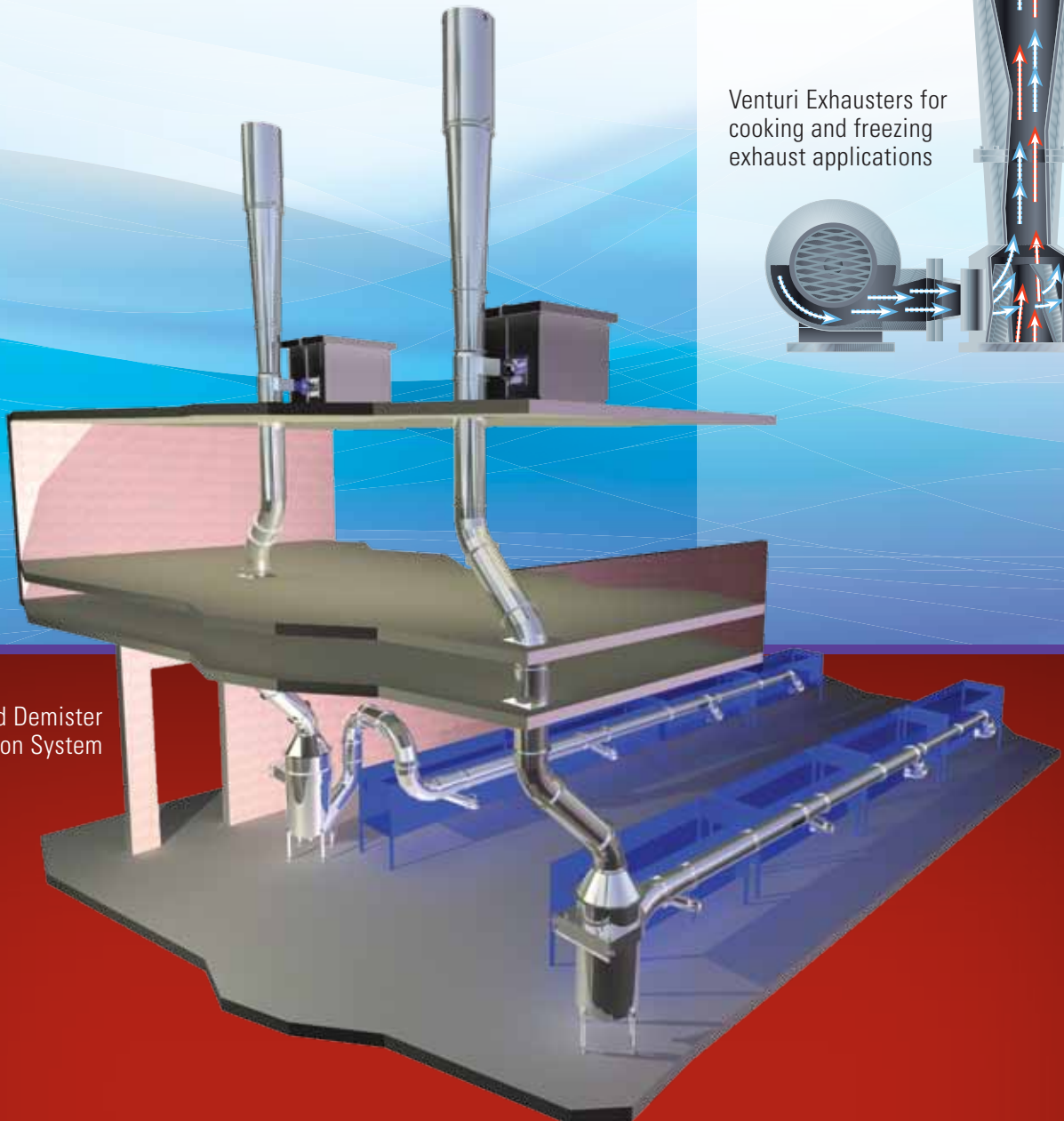

Food Industry Exhaust & Exhaust Filtration Systems

SOLUTIONS FOR:

Fryers, Ovens, Freezing Tunnels, Microwave Ovens, Blanchers, Char-Markers, Baking Applications, Mixers, Caustic Chemicals or Acids and High Temperature Applications



Venturi Exhausters for cooking and freezing exhaust applications

Engineered Demister Exhaust Filtration System

The Quickd

Since 1953 Quickdraft has provided pneumatic conveying and exhaust solutions specifically engineered to solve our customers' production problems and to enhance productivity and profitability. Quickdraft serves many industries including food processing, pulp and paper, metals processing, film, foil, non-wovens, fiberglass, plastics and rubber, among others. Many of these applications demand exacting system design requirements and dependable 24-hour/7-days a week operation of our equipment with minimal maintenance. Our experience in these varied applications provides us the ability to develop unique, dependable solutions for our customers.

Venturi Powered Solutions

At the very core of Quickdraft's exhaust technology is its Venturi, designed and manufactured to provide a clear flow path for various applications. With Quickdraft's venturi-powered exhaust system, there are no moving parts in the airstream.

The Venturi is powered by a pressure blower. The blower injects air at high velocity and pressure through a plenum chamber controlled by a nozzle in the Venturi. This creates the Venturi effect and induces the flow of air upstream of the Venturi.

The blower sits outside of the duct and handles ambient air. This arrangement results in a very dependable Venturi exhaust system that is nearly maintenance-free. It also allows the blower to be constructed of carbon steel, resulting in lower system costs.

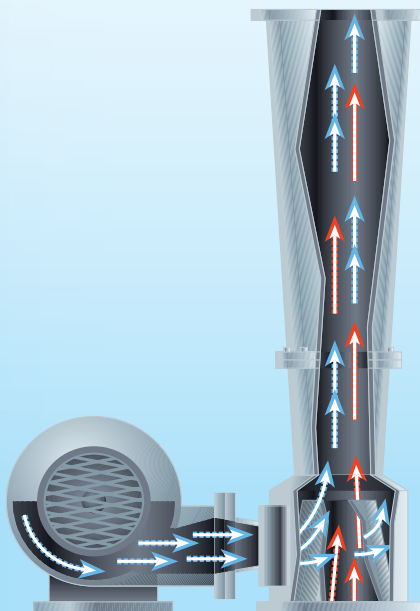

raft Venturi

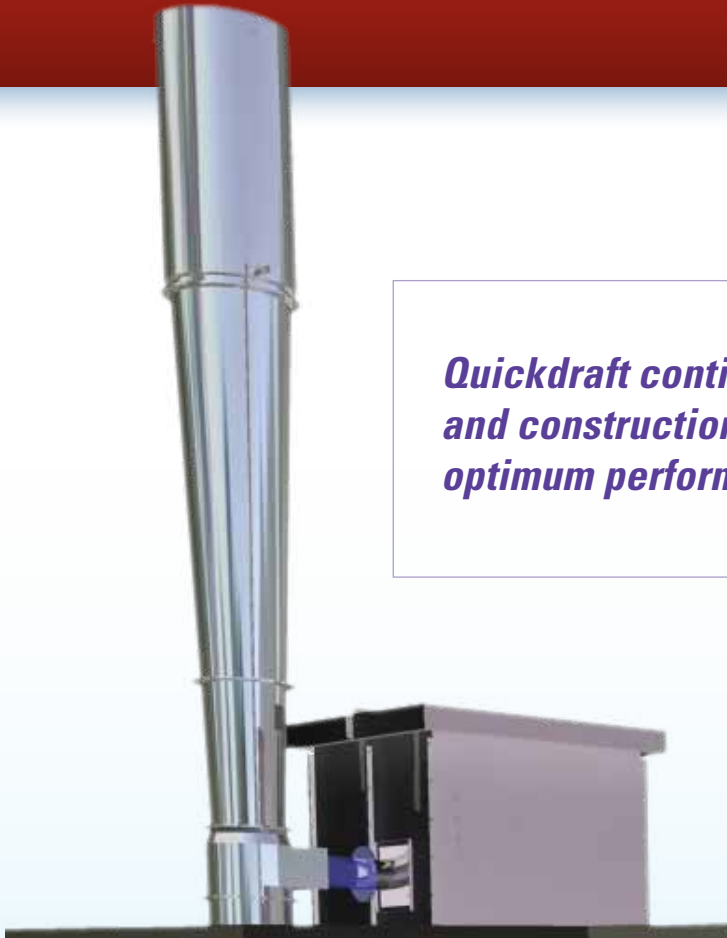

Quickdraft continues to improve the design and construction of its Venturi to ensure optimum performance.

2

Designed for Optimum Performance

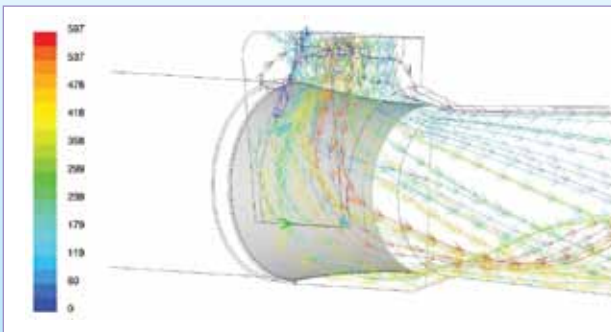

Superior design and precision manufacturing give the Quickdraft Venturi its uniqueness in creating effective suction and efficient acceleration.

Advantages

- There are no obstructions in the flow path and all moving parts are external to the duct
- Little or no maintenance
- Consistent, dependable performance
- Duct can be thoroughly cleaned without harming the blower
- Designed for 24/7 operation
- Long service life
- The blower can be located remotely from the Venturi
- Sound reduction equipment available for all applications

Demister Exhaust Filtration Systems

- Filter grease, oil and other contaminants from exhaust air stream
- Eliminate grease and oil accumulation on roof
 - Prevent roof damage/extend life
 - Protect other roof mounted equipment
 - Eliminate cost, time and expense of roof cleaning
 - Reduce problems from pests
- No moving components, easy to maintain
- Three stage filtration:
 - Centrifugal
 - Wet scrubber
 - Demister Pad Filter
- 99% efficient for particles 10 micron and greater
- 75% efficient for 2-3 micron particulate
- Water recirculation reduces water consumption and operating costs
 - Provides required flow for maximum filtration efficiency
 - Includes pressure regulator and gauge for flow adjustment
 - Automated grease/oil skimming feature available
- All stainless construction
- Low maintenance

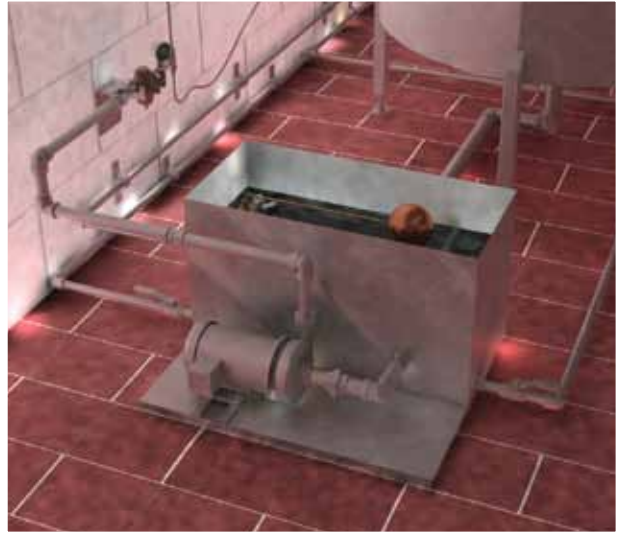

Water Recirculation System



Complete Equipment Supply and Engineering Service Support

- Exhaust duct layout and supply
- 3D installation drawings
- Control system or integration with existing controls
- All stainless flow path
- Balancing dampers, access doors and drains
- Insulated exhaust duct
- Start-up assistance and installation supervision
- Evaluation of existing systems

Patty / Meatball Production

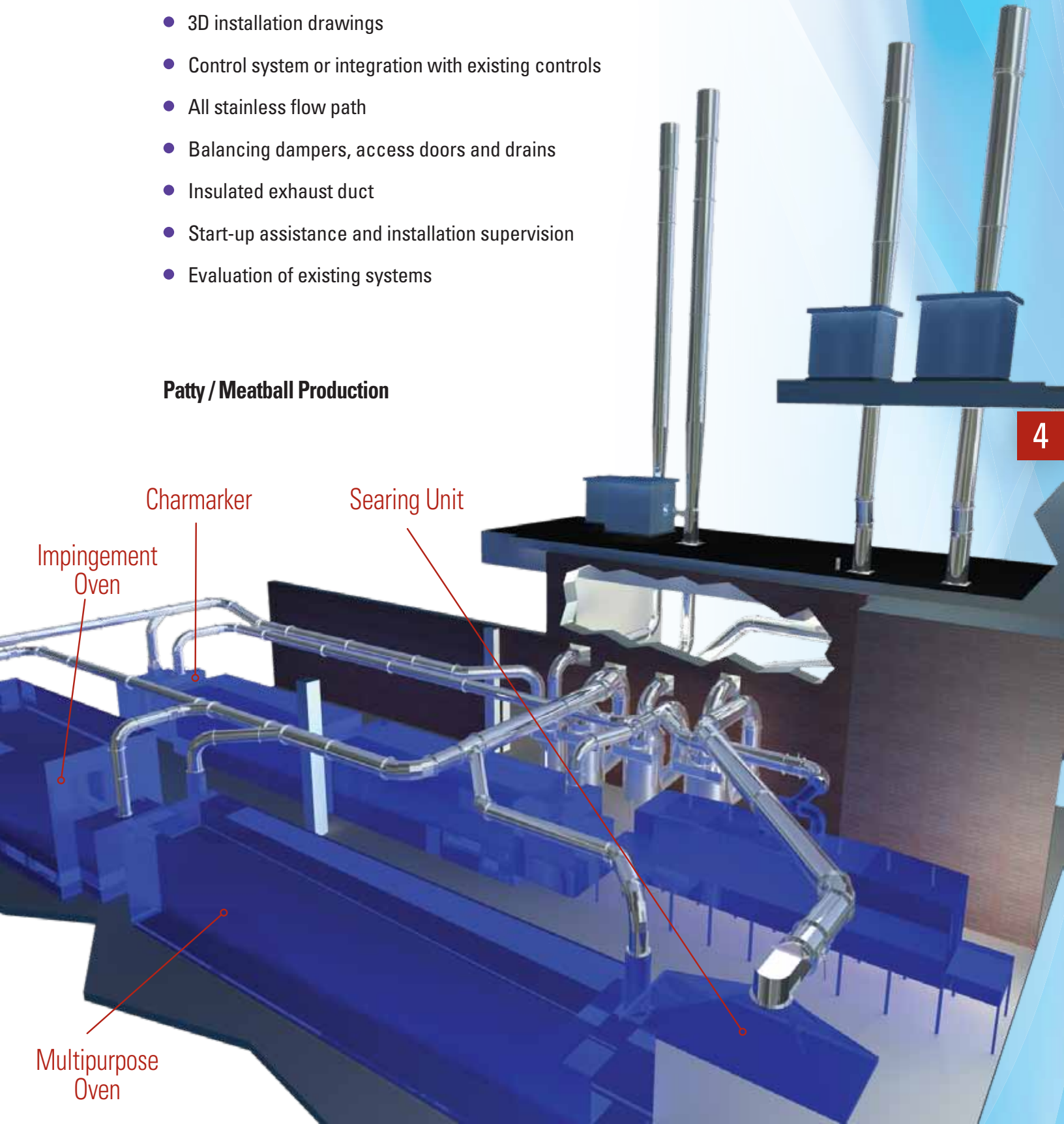

Cryogenic Exhaust

- Excellent solution for cryogenic applications venting nitrogen or carbon dioxide gases
- No moving parts come into contact with the vapors, eliminating ice build-up on the impeller
- Reduce down time and lost production by eliminating fan failure due to freezing
- Eliminates frequent motor replacement due to wheel seizure
- Minimizes the need for expensive conditioned air used to prevent in-line fan freezing
- Heat tracing and insulation of the stack is available
- Equipment in the flow path is constructed of 304 stainless steel
- Simple installation

5

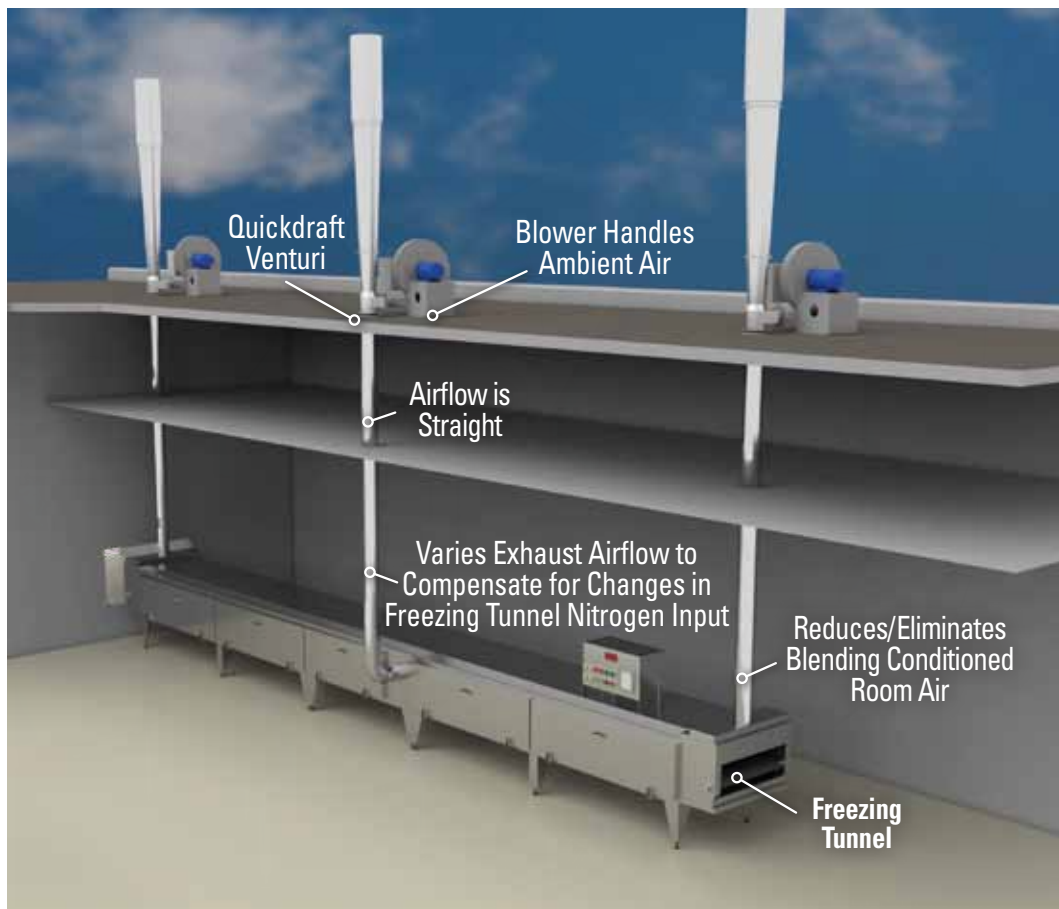

Velocity Reduction Chambers

- Prevent material carryover onto roof
- Food particles fall out of airstream inside the chamber
- Easy access to the chamber for cleaning
- Improve pest control by eliminating food source, improving food safety
- Reduce maintenance costs by reducing the number of roof cleanings needed
- Extend the service life of roof

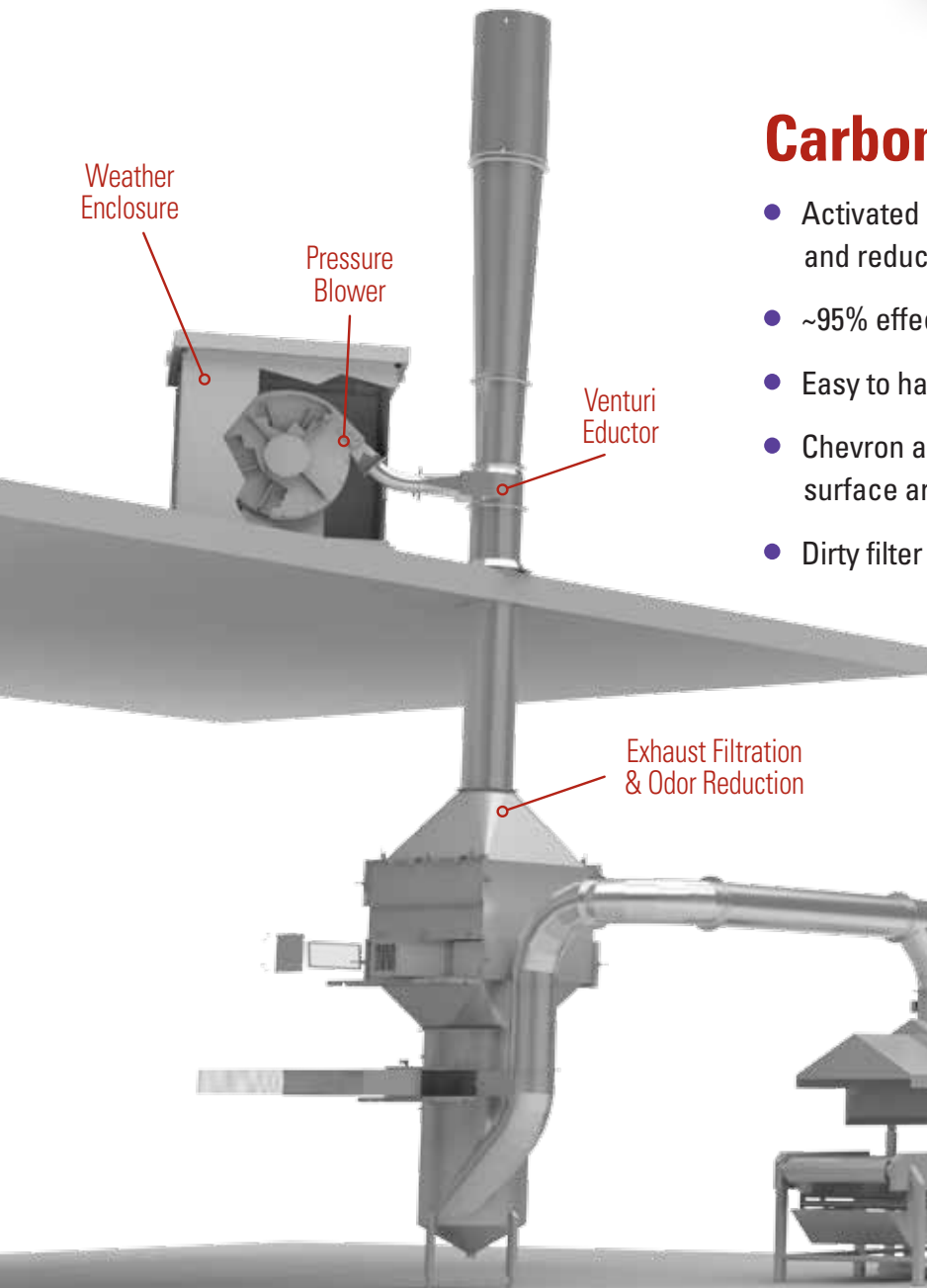
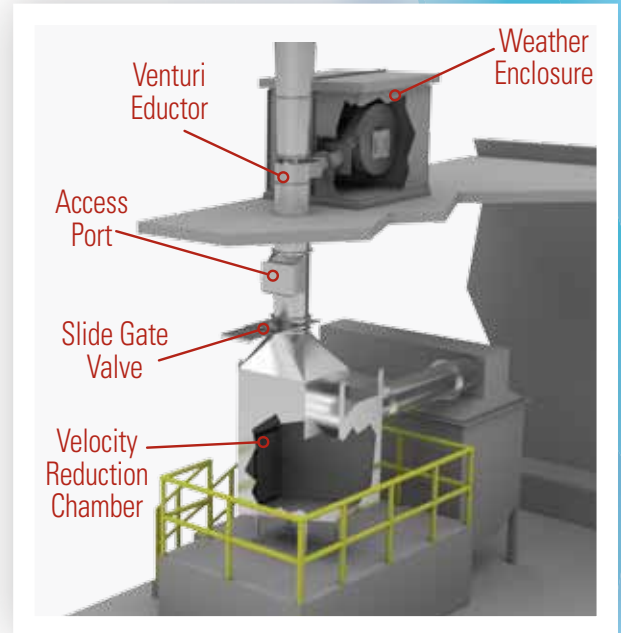

Carbon Filters

- Activated carbon mix to increase efficiency and reduce odor
- ~95% effective for odor reduction
- Easy to handle slide-in trays
- Chevron arrangement for increased surface area
- Dirty filter indicator available

Bacon Oven Grease Demister Case Study

Fresh Mark controls grease discharge from their microwave bacon ovens with Quickdraft's exhaustor demister units.

Exhausting grease-laden air is not a simple matter. The exhaust's high temperature and high humidity adversely affect fan bearing life, and grease particulates carry over and adhere to fan impellers, throwing them out of balance and seriously damaging the fans. Some of that same particulate will land on the roof and create pools of grease.

Fresh Mark contacted Quickdraft Inc. to discuss our Venturi Exhauster. This exhauster has no moving parts in the air stream, and the unit's fan handles only uncontaminated ambient air. Problems associated with bearing and shaft failure and with impeller imbalance don't arise. To significantly reduce grease discharge, Quickdraft developed and added a grease demister section prior to the Venturi. The cylindrical section incorporates an exclusive multi-layer filter element that captures the

bulk of the grease, while an internal wash down spraying system both purges the filter from the underside of the pad and entrains grease particles in the water spray, pulling the grease down through the drain. The exhauster and demister are tied into the microwave oven controls so that the units will start and stop in conjunction with the oven's operation. Exhausters can be fitted with caustic wash down sprays.

According to Fresh Mark, the plant's roof "looks 100-percent better." The Venturi Exhauster has also allowed Fresh Mark to control the oven environment. Unobstructed exhaust air flow eliminates internal arcing, and improves drying performance by capturing and removing the released moisture early in the microwaving process. The result is maximized product throughput while consumed energy is reduced.

Venturi Exhauster at Fresh Mark's Salem, Ohio plant



New microwave bacon ovens



Demister Filtration Unit



Ovens produce bacon bits and bacon strips



1525 Perry Drive S.W. | Canton, Ohio 44710
(330) 477-4574 | Fax: (330) 477-3314

sales@quickdraft.com
quickdraft.com